

ISO 40 MM

THE ASCOT ALL ROUNDER

The ISO 40 mm sectional door is Ascot's best-selling model, offering superior heat insulation and sound absorption with its sleek, micro-profiled panels. The design options are virtually limitless, allowing each door to be tailored precisely to its intended application. Customers can select from a wide range of window types, sizes, and 19 standard colours in Ascot's standard range.

Built for Versatility

Developed with state-of-the-art techniques, the ISO 40 mm sectional door is crafted for durability and precision. Notable features include metal or aluminum end caps, robust reinforcement profiles, and an anodized aluminum base profile seamlessly integrated from view. This design flexibility makes the ISO 40 mm sectional door a true all-rounder, blending performance, affordability and adaptability across diverse applications.

ISO 40 XXL

Extra large available till
10.000 mm x 6.000 mm (bxh)

UNIQUE
IN THE
MARKET

Largest number of standard colours in the market!

Microprofiling, our standard finish, is available in 19 standard colours at no additional cost.

"Sandwich"-construction ISO 40 panel

Panel thickness: 40 mm
Insulation value: U=0,52 W/m²K
Specific density PU Foam: 40 kg/m³

A	Paint layer:	19 standard colours (outside)
B	Zinc coating:	275 g/m ²
C	Steel sheet:	0,5 mm
D	Zinc coating:	275 g/m ²
E	Primer coating:	
F	PU high density foam:	g=40 kg/m ³ , Free of CFK and H-CFK
E	Primer coating:	
D	Zinc coating:	275 g/m ²
C	Steel sheet:	0,5 mm
B	Zinc coating:	275 g/m ²
A	Paint layer:	RAL 9002 (inside)

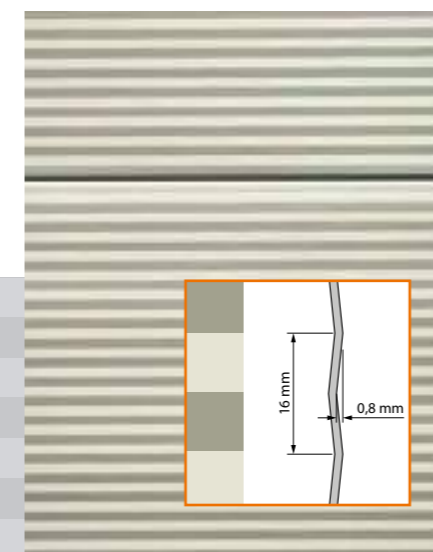
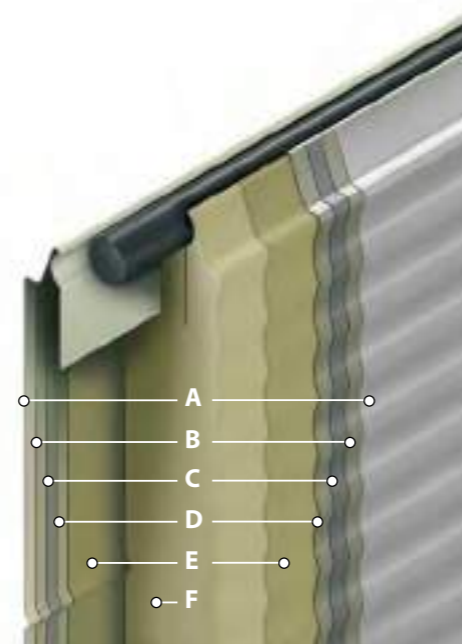

U-VALUE ISO 40mm 5000X5000 MM:

- sectional door: 0.91 W/m²K
- sectional door with insulation ++package: 0.80 W/m²K



ISO 60 MM

ENHANCED INSULATION AT A COMPETITIVE PRICE

The ISO 60 mm sectional door provides superior insulation and sealing, ideal for areas where climate separation is essential. This model helps maintain stable temperatures in production halls or storage spaces, offering robust weather resistance along with excellent sound-absorbing and heat-insulating properties. Its micro-profiled sheet steel panels are designed to withstand various environmental challenges.

High-Performance Insulation Value
The panels of the ISO 60 are constructed using a „sandwich“ method, where CFC-free polyurethane foam is sandwiched between two galvanized steel plates. This structure not only boosts insulation but also enhances durability. Available in 14 standard RAL colours, the door can also be customized with a wet-paint acrylic coating in any RAL colour to meet specific design needs.



“Sandwich”-construction ISO 60 panel

Panel thickness: 60 mm
Insulation value: $U=0,35 \text{ W/m}^2\text{K}$
Specific density PU Foam: 40 kg/m^3

A	Paint layer:	14 standard colours (outside)
B	Zinc coating:	275 g/m ²
C	Steel sheet:	0,5 mm
D	Zinc coating:	275 g/m ²
E	Primer coating:	
F	PU high density foam:	$g=40 \text{ kg/m}^3$, Free of CFK and H-CFK
E	Primer coating:	
D	Zinc coating:	275 g/m ²
C	Steel sheet:	0,5 mm
B	Zinc coating:	275 g/m ²
A	Paint layer:	RAL 9002 (inside)

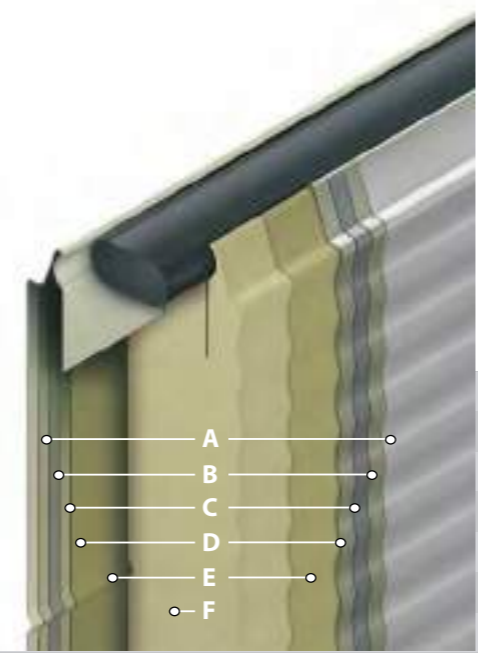

Microprofiling, the standard, in 14 standard colours at no extra charge.

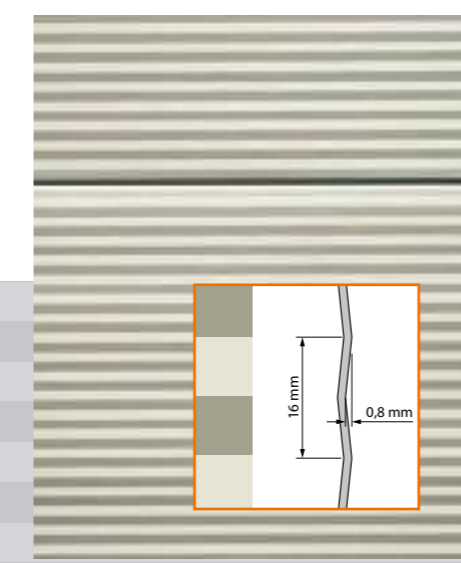

U-VALUE ISO 60mm 5000X5000 MM:
 • sectional door: 0.78 W/M2K
 • sectional door with insulation ++package: 0.71 W/m²K



ISO 80 MM

MAXIMUM INSULATION
WHEN ENERGY SAVINGS
ARE AN ABSOLUTE MUST

As energy efficiency standards for industrial and commercial buildings continue to tighten, the need for high-performance access doors becomes more critical. The ISO 80 sectional door is the next step in insulation, following the success of the ISO 40 and ISO 60 models. It utilizes a polyurethane foam core, with a thermal break between the interior and exterior of the panels, ensuring enhanced thermal insulation.

Optimal Insulation for Energy Savings
With a U-value of 0.25 W/m²K, the ISO 80 sectional door is ideal for environments where maintaining a stable temperature is essential, such as cold storage facilities, industrial halls, and logistics centres. The door's exceptional insulation properties help prevent heat loss, making it a perfect choice for situations where temperature control is critical for both ecological and economic reasons. This door complies with current energy-saving regulations, providing customers with an effective solution to meet modern energy efficiency standards.



U-VALUE ISO 80mm 5000X5000 MM:
• sectional door: 0.46 W/M2K

"Sandwich"-construction ISO 80 panel

Panel thickness: 80 mm
 Insulation value: U=0,25 W/m²K
 Specific density PU Foam: 40 kg/m³
 Panels: Exterior microline profiled
 Inside stucco design

A	Paint layer:	RAL 7016, 9002 en 9006 (outside)
B	Zinc coating:	275 g/m ²
C	Steel sheet:	0,5 mm
D	Zinc coating:	275 g/m ²
E	Primer coating:	
F	PU high density foam:	g=40 kg/m ³ , Free of CFK and H-CFK
G	Paint layer:	RAL 9002 (inside)

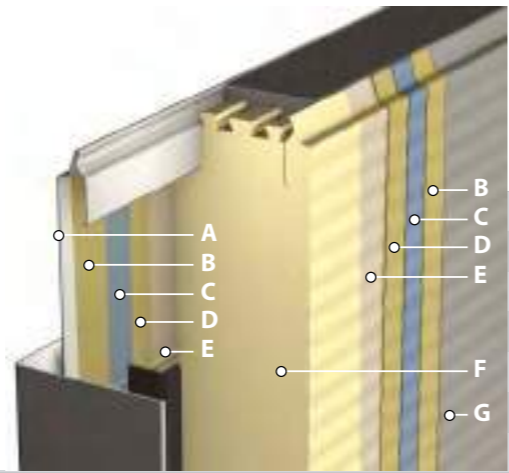

Microprofiling, the standard, in 3 standard colours at no extra charge.

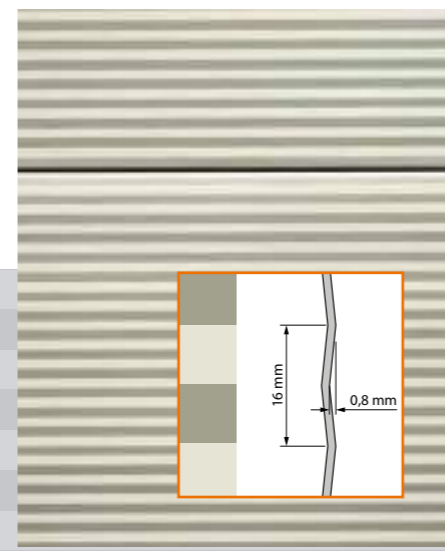

Floor sealing
For optimal bottom sealing, Ascot's doors employ a double bottom rubber seal with inward-curved edges. This design, combined with a special PVC profile, reduces thermal transfer for better insulation and energy efficiency.

PARTICULARS

ISO 40 | 60 | 80

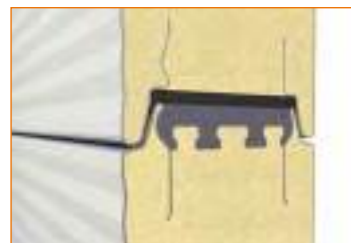
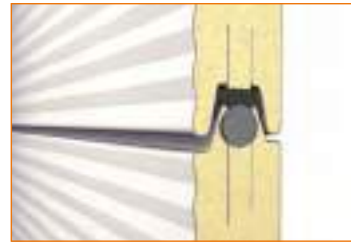

Connection panels

The connection joint between the panels of ISO 40, ISO 60, and ISO 80 doors is both wind- and watertight, thanks to a foam rubber cord placed between the panels. This design ensures that the inner plate of the door remains separated from the outer plate, which contributes to optimal insulation.



ISO 40/60

Standard Frame

The connection between the door leaf and the vertical tracks in a standard corner frame ensures a strong, tight seal between the side of the door and the building. This design prevents gaps and enhances the overall durability and insulation of the door system.



ISO 40/60/80

Heavy-duty Frame ZHK

This frame is used for doors with dark colours to prevent the door from warping due to sun exposure. When heated by the sun, the door can bow outward, potentially impacting the upper lintel. The heavy corner frame effectively prevents this from happening, maintaining the door's structural integrity.

ISO 40



ISO 60/80

Floor Sealing

For optimal bottom sealing, Ascot's doors employ a double bottom rubber seal with inward-curved edges. This design, combined with a special PVC profile, reduces thermal transfer for better insulation and energy efficiency.

ISO 40/60/80



External Lock for Every Situation:

Depending on the panel thickness, the type of cylinder, and the desired locking position, an external lock can be customised to meet these specific requirements and preferences.

ISO 40/60/80



Wind load











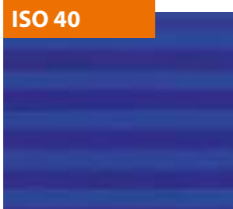

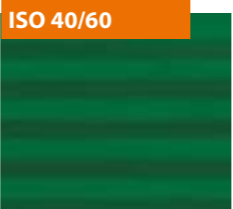
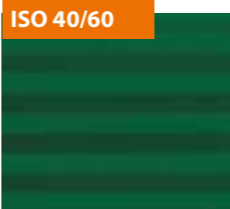

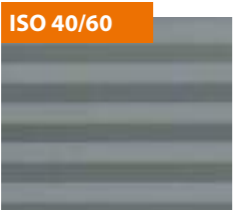
Depending on the door's width, Ascot reinforce it with specialised profiles. These reinforcement profiles ensure that the door meets all relevant regulations and standards regarding resistance to heavy wind loads.



ASCOT STANDARD RANGE

Standard colours

At Ascot Doors, architects have the freedom to explore design and colour options, enhancing the aesthetic of modern industrial architecture. The micro-profiled sheet steel used for our doors offers a versatile canvas, and with 19 standard colours* available, each door can be customised to fit perfectly within any design concept. Best of all, there are no additional costs for these colours. Thanks to the durable and colourfast coil coatings, Ascot's doors can be seamlessly integrated into your company's branding or corporate identity. If you have specific colour requirements, a selection of custom colours are available. However, it is recommended to avoid dark colours on sectional doors exposed to prolonged sunlight, as this can lead to deflection of the panels.

 ISO 40/60 RAL 3000	 ISO 40 RAL 5003	 ISO 40/60 RAL 5010	 ISO 40/60 RAL 6005	 ISO 40/60 RAL 6009
 ISO 40/60 RAL 7005	 ISO 40/60 RAL 7015	 ISO 40/60/80 RAL 7016	 ISO 40 RAL 7021	 ISO 40/60 RAL 7022
 ISO 40/60 RAL 7035	 ISO 40/60 RAL 8014	 ISO 40/60/80 RAL 9002	 ISO 40 RAL 9005	 ISO 40/60/80 RAL 9006
 ISO 40/60 RAL 9007	 ISO 40/60 RAL 9010	 ISO 40 Goosewing	 ISO 40 Merlin	<div data-bbox="1160 1354 1377 1533" data-label="Text"> <p>LARGEST NUMBER OF STANDARD COLOURS IN THE MARKET! CHOOSE FROM 19 COLOURS AT NO EXTRA CHARGE.</p> </div> <div data-bbox="1329 1543 1418 1606" data-label="Text"> <p>UNIQUE IN THE MARKET</p> </div>
		 ISO 40 RAL 7016	 ISO 40 RAL 9002	

STUCCO Profiling

In addition to the 19 ISO40 standard colours*, we also offer 3 standard colours* for ISO40 Stucco profiling.

*Pictured colours are an approximation of the final colour effect.

* Dark colours should be avoided for double-walled steel doors facing the sun, as possible slat deflection can damage the door. All colours are based on the respective RAL colour. The illustrations of colours and surfaces are not binding for technical printing reasons.

WINDOW VERSIONS

The function of windows

ISO sectional doors can be fitted with plexiglass windows, ensuring excellent light entry and visibility. The standard window options feature elongated shapes with straight or rounded corners, available in single or insulating double glazing. For added security, we offer reduced height rectangular windows with rounded corners, designed for burglary resistance. For a unique design touch, choose round windows or creative patterns.



 ISO 40/60/80 15%*	 ISO 40 3,2%*	 ISO 40 3,8%*
 Lots of light, lots of visibility	 630 mm 557 mm 230 mm 305 mm Rounded corners (r=60 mm), good insulation value	 663 mm 583 mm 265 mm 345 mm Rounded corners (r=100 mm), good insulation value
 ISO 40/60/80 4,35%*	 ISO 40/60/80 1,15%*	 ISO 40 1,23%*
 681 mm 602 mm 289 mm 368 mm Straight corners, good insulation value	 610 mm 545 mm 85 mm 145 mm Limited height, burglar-proof	 325 mm 250 mm Fine round windows

* Percentages depend on door size and total number of windows.

TRACK SYSTEMS

HIGH QUALITY MODULAR ASSEMBLY

OPTIONS

Ascot's track systems are designed to be modular and versatile, suitable for ISO, ALU, and Panorama doors. The focus on certified quality and durability ensures that both the track systems and spring packages meet high standards, providing reliable performance over time.

Spring buffer

The spring buffer, mounted robustly, provides an initial push for the door to lower from its horizontal position. Depending on the door configuration, either a door stop or a spring buffer of varying lengths will be supplied to ensure smooth operation. This feature helps manage the door's movement and contributes to its durability.



Floor plate

The floor plate ensures proper alignment of the track with the floor, functioning in conjunction with the distance profile to maintain the correct spacing between the tracks.



NEW NEW NEW

We offer track systems and additional components made of stainless steel in European AISI304 quality.

- Track systems T450, T400, T500 in stainless steel
- Fixing sets in stainless steel
- Track hangers in stainless steel
- Bearing plates in stainless steel



M8 bolt connections

The standard connections between the sheet metal parts and track profiles are made with M8 bolt connections. This approach, combined with the carefully pre-assembled components, allows for faster installation times.



Cable position

The modular structure of our track systems and sheet metal components allows us to always ensure an ideal cable position in relation to the vertical tracks. This ensures optimum safety and operational reliability.



Safety track

A safety running track ensures that the wheels cannot run out of the track. For extra safety, the cable is safely encapsulated in the construction.

TRACK SYSTEMS

Ascot Door's track systems are designed to adapt to various installation requirements, ensuring that doors can be mounted securely in different building types. With varying available space and construction constraints, Ascot offers a range of track variants that can be customized to fit any situation.

A solution for every variant

T 200

max. 16.5 m²

Low-profile track system, internal cables + steel support profile

A= 200 mm
B= opening height + 1.000 mm
Width max. 5.500 mm

T 240

max. 28 m²

Low-profile track system, internal cables + steel support profile

A= 240 mm
B= opening height + 1.000 mm
Width max. 7.000 mm

T 340

max. 22 m²

Normal track system, spring package rear + steel support profile

A= 350 mm
B= opening height + 750 mm
Width max. 6.500 mm

T 450

max. 50 m²

Normal track system (standard)

A = 430-510 mm
B: Pull cord = DH + 650 mm
Manual hoist = DH + 850 mm
Electric hoist = DH + 850 mm

T 450 DDE

max. 10.2 m²

Details normal track system with low-lying pre-assembled spring axle

A = 825 mm
B: Pull cord = DH + 650 mm
Manual hoist = DH + 850 mm
Electric hoist = DH + 850 mm
Width max 3.200 mm

Helix

max. 25 m²

Details normal track system with low-lying pre-assembled Helix spiral

A= 1100 mm
B= 1200 mm
Width max 5000 mm
Height min. 2500 mm

T 600

max. 25 m²

Helix S600 Horizontal track system

A= 600 mm
B= daghoogte + 265 mm
Width max 5000 mm

T 400

max. 50 m²

Raised track system

A= levy + 400 mm
B: Pull cord = DH - levy + 650 mm
Manual hoist = DH - levy + 850 mm
Electric hoist = DH - levy + 850 mm

T 400 hF

max. 20 m²

Elevated track system with low-lying spring axle + steel support profile

A= levy + 200 mm,
B: Pull cord = DH - heffing+ 650mm
Manual hoist = DH - levy+ 850mm
Electric hoist = DH - levy+ 850mm
Width max. 4.500 mm
Minimum levy 1.450 mm

T 400 DS

max. 10.2 m²

Elevated track system with low-lying spring axle

A= levy + 200 mm
B: Pull cord = DH - levy + 650 mm
Manual hoist= DH - levy + 850 mm
Electric hoist = DH - levy + 850 mm
Width max. 3.200 mm
Minimum levy 1.700 mm

T 400 DDE

max. 10.2 m²

Pre-assembled spring axle

A= levy + 200 mm
B: Pull cord = DH - levy+ 650 mm
Manual hoist = DH - levy + 850 mm
Electric hoist = DH - levy + 850 mm
Width max.. 3.200 mm
Minimum levy. 1.700 mm

T 500

max. 35 m²

Vertical track system

A= opening height + 560 mm

T 500 hF

max. 20 m²

Vertical track system with low-lying spring axle + steel support profile

A= opening height+ 400 mm
Width max. 4.500 mm

T 500 DS

max. 10.2 m²

Vertical track system with low-lying spring axle

A= opening height + 400 mm
Width max. 3.200 mm

T 500 DDE

max. 10.2 m²

Pre-assembled spring axle

A= opening height+ 400 mm
Width max. 3.200 mm

CONTROLS ON THE CONTROL PANEL



T75 Basic Control

T75 control is a basic control for industrial sectional doors. The T75 is equipped with a 3-button control and connections for closing strips, light curtains, cable breakage switches and wicket door switches (not with low threshold). In addition, the T75 can optionally be equipped with a 433 MHz radio module. It is a deadman control, which is expandable to a limited extent to an impulse control.



T100 Premium Control

T100 control is a comfortable premium control. The T100 features a display integrated in the cover, a 3-button control, a half-opening button and all the necessary connections for locking tracks, light curtains, cable-break switches and wicket door switches. In addition, functions such as automatic closing or door locking can be programmed. The controller is suitable for a motor power of 3 kW. There are also connection options for additional controls.



For operating your sectional doors, Ascot offers a wide range of high-quality control elements that can be built into the control box of the door system. In addition, many elements can also be mounted on the inside or outside wall or on a column, for example. These include safety devices, switches, remote controls, flashing lights and more.



Emergency stop

When current legislation requires it, it is possible to equip the console with an emergency stop button.



Key switch

You can disable the key switch on the control cabinet to prevent unauthorized operation of the door. Only authorized individuals possess a key, which, when activated, allows them to operate the door.



DCC 80 Drive

Introducing the latest innovation in drive technology: the new DCC 80 drive, powered by DC technology for industrial doors. The DCC 80 combines the benefits of various drive and control types in a highly cost-effective solution, making it the ideal foundation for your service. The DCC 80 is suitable for all types of sectional doors (40/60/80 mm) and compatible with all standard hardware types.



Motor with emergency chain

All drive systems come standard with a mechanical emergency control on the reduction gear of the electric motor. This allows the sectional door to be opened even in the event of a power failure. The function must be activated and deactivated manually using switch cords, after which the reduction gear can be operated by the emergency chain.



Motor with decoupling

A drive with a decoupling device is also available. In this case, the reduction gear is disconnected from the spring shaft using cables, allowing the sectional door to be opened more quickly by hand in the event of a malfunction. Of course, a sectional door with a decoupling device is also equipped with spring break protection for added safety.



2 position switch

This switch allows you to select between two preset positions. For example, switch it once will open the door to person-height, while switch it twice will open the door fully. This option is ideal for energy savings, as the door doesn't always need to be opened completely.



Main Switch with Padlock

When servicing the door system, the main switch can be used to disconnect the power. By securing the switch with a padlock, you prevent third parties from accidentally restoring power while maintenance is in progress.

Signaling and Detection via Wireless Transmission



Wireless Communication

Typically, the control box and the connection box on the door leaf are connected by a flexible spiral cable, which can be inconvenient and prone to damage. To address this, Ascot Doors offers connection boxes with an integrated battery that wirelessly transmits signals, such as those from detection devices, to the control cabinet.

EXTRA OPERATING ELEMENTS

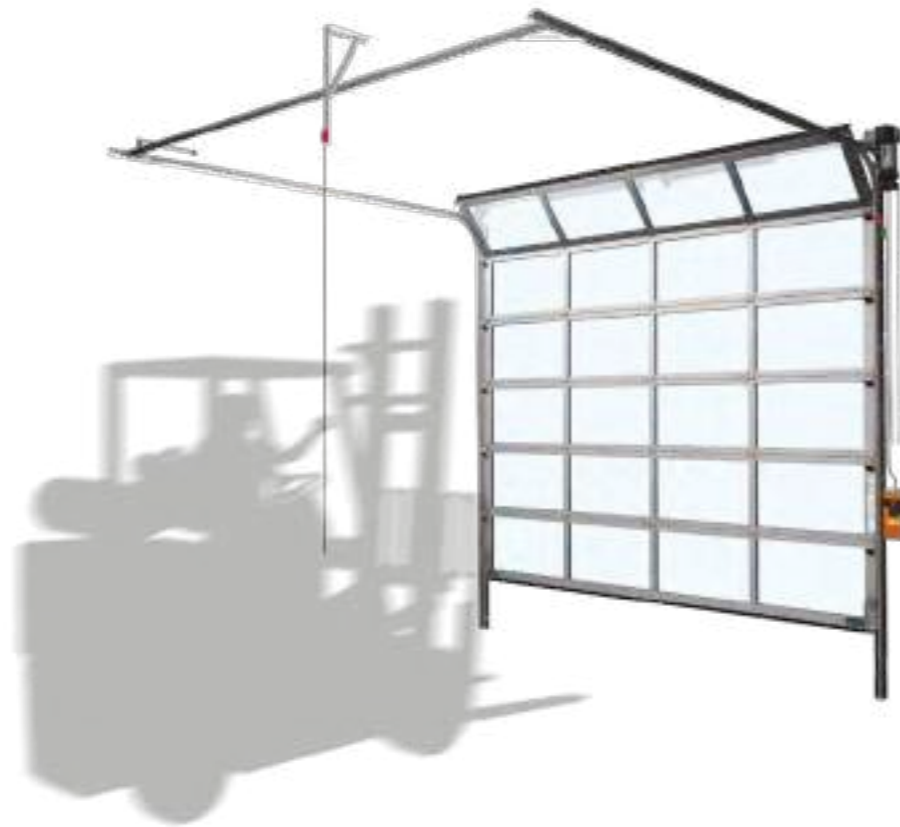

Additional control panel

If a door needs to be operated from multiple rooms or remotely, such as from a porter's lodge, an additional control panel is the ideal solution. This convenient „Up-Stop-Down“ box includes all the buttons found on the standard control box, providing full functionality in a compact form.



Traffic lights and beacons

To prevent injury to persons and damage to the sectional doors and goods, traffic lights and beacons are installed on both sides of the door. Beacons warn people and switch on before a door opens. Traffic lights regulate traffic and prevent damage to doors.



Key switch

The door can be operated with a separate key switch, which can be attached to the outer wall. There are two variants: the flush-mounted version, which is often used in new buildings, and the surface-mounted version, which can be retrofitted in renovation projects without any cutting and breaking.



Electric code panel

To make a doorway accessible 24/7, a door can be operated with a code panel. This is a particularly practical solution for keeping protected pick-up or delivery points accessible day and night for transport and courier companies.



Pull switch

The pull switch allows the forklift driver to operate the door without having to dismount. It's the perfect solution for environments with many staff members, where providing each person with a hand transmitter is not practical. The pull switch is typically mounted on a stand several metres in front of or behind the door for easy access.



Remote control

Integrated receivers in the control box allows for easy upgrading to a remote-controlled system. You can choose from 1-, 2-, or 4-channel hand transmitters, enabling you to operate up to four different doors..



Safety is crucial when operating vertically moving, often heavy sectional doors. That's why Ascot Doors offers both mechanical and electrical safety systems to prevent the door from hitting people, vehicles, or obstacles, thus avoiding personal injury or damage to the door and/or goods. However, excessive security measures can often be unnecessary and counterproductive, as they may require additional installation and space, and components can interfere with or damage each other. Ascot advises focusing on compliance with the relevant regulations, ensuring optimal security systems that are TÜV Nord certified and meet the highest standards.



Spring break protection

The European standard EN-13241 requires that a sectional door must never fall uncontrollably. Therefore, a manually operated sectional door should be equipped with spring break protection as standard. This protection blocks the spring shaft in the event of a spring failure, preventing the door from falling uncontrollably.

In sectional doors with a drive, the function of spring break protection is provided by a self-locking gearbox, so no additional spring break protection is needed. However, if a motor with decoupling is selected, spring break protection must be used.

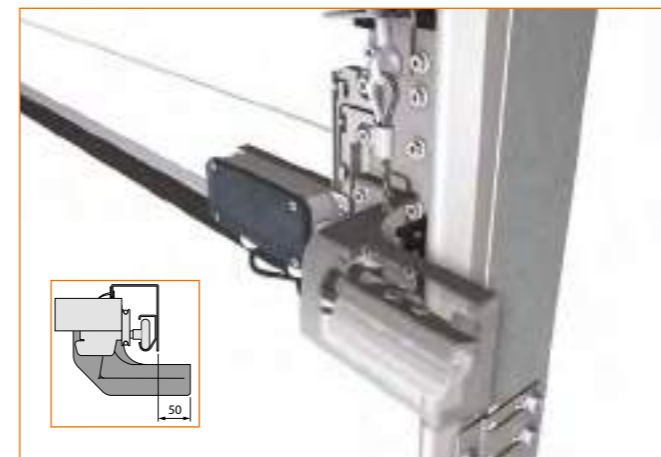

Cable break protection

TÜV regulations state that the breaking load of both lifting cables must be six times the weight of the balanced door leaf. If the lifting cables meet this requirement, cable break protection is not necessary. However, if this safety margin cannot be guaranteed, the door will be equipped with cable break protection as standard. In the event of a cable break, this protection activates catch blades in the guide to prevent an uncontrolled closing movement. When cable break protection is used, an additional 50 mm of space is required beside the track.

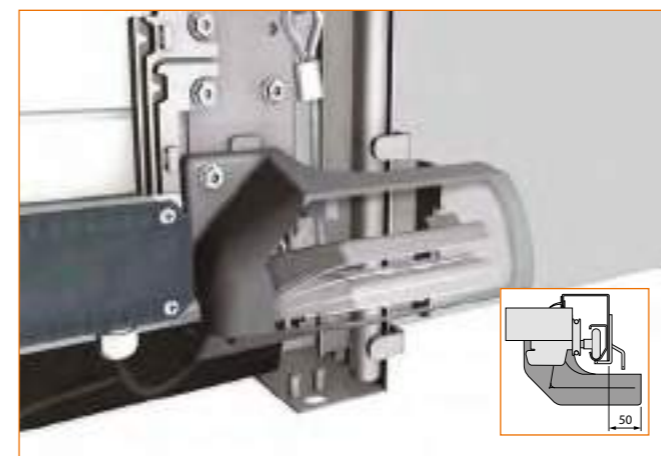

Anti-Lift Protection

Since a sectional door is suspended on flexible cables, an unlocked door can potentially be lifted. The anti-lift protection, particularly for light electrically operated doors, prevents this. Without anti-lift protection, this type of door can be more susceptible to burglary. Manually operated doors are equipped as standard with a spring-loaded mechanical sliding bolt and a lock in the track. When anti-lift protection is used, an additional 50 mm of space is required beside the track.

Electric contact strip

The electrical contact strip is perfect for moisture-sensitive environments, featuring a compact, insulated switching chamber that helps reduce condensation. It is also resistant to lateral deflection, making it less affected by wind load and ensuring reliable performance during heavy rain or thunderstorms. With an IP 67 rating for durability, the contact strip is made from 100% recyclable TPE material, which is UV-resistant, lightweight, and resistant to aggressive chemicals, ensuring a long lifespan.



Slack cable protection

This protection is installed on both lifting cables and immediately shuts off the electric motor if one of the cables breaks or sags.



Safety

Sectional doors can be optionally equipped with a light curtain. The light screen is formed with transmitter and receiver sensors in the tracks, so the cabling is in the tracks and not on the door leaf.

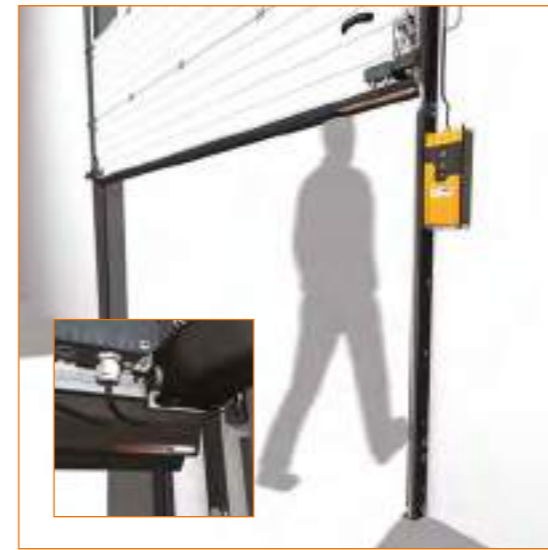

Standard safety edge protection

The safety edge protection is integrated into the door's sealing rubber, featuring a transmitter and receiver. If the signal transmission is interrupted by an object or person, the door stops and reverses. The maximum contact pressure with the rubber is 40 kg. If products cannot withstand this pressure, the leading under-run protection should be selected instead.



Leading Edge protection

With this option, the leading edge protection extends 8 cm in front of the door. If the bottom of the door comes close to an obstacle, a signal is immediately sent to the motor, halting the door's movement and causing it to reverse. This protection works without making contact with people, goods, or vehicles.



Stationary photocell protection

Photocell protection is required for motors with impulse control, where the user cannot see the door movement while operating it. There are two types: one with a transmitter and reflector, and one with a transmitter and receiver. In both systems, the transmitter is mounted on the track near the control cabinet, with the reflector or receiver placed on the opposite track. If the beam between the transmitter and reflector/receiver is interrupted by an object, a signal is sent to the motor to stop and reverse the movement. The reflector system is sensitive to dust and moisture contamination, while the receiver version is not.

